

# SPECIFICATION SHEET

## MODEL: UC-XL

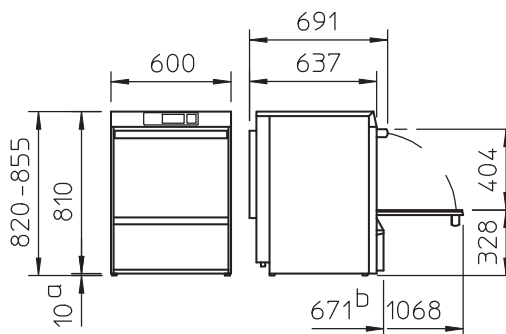

### TECHNICAL INFORMATION

Dimensions	600w x 637d x 820-855h
Rack Dimension	500 x 500 or 500 x 540
Clear Entry Height	404
Rinse Water Consumption	2L Per Cycle

### WATER CONNECTIONS

Connection Point	3/4 inch (19mm)
Inlet Temperature	60c Max
Flow Rate	4 L/Min
Flow Pressure	1 - 6 bar

### ELECTRICAL

Single Phase (Standard)	240v 1P 50Hz - 15amp (TCL 3.2Kw)
3 Phase (Optional)	415v 3P 50Hz - 15 or 20amp (TCL 7.9Kw)

### GENERAL DATA

Weight (Net/Gross)	69/79Kg
Tank Capacity	15.3L
Noise Emission	55dB(A)
Cycle Times	60/90/180 Seconds (Adjustable)

### STANDARD INCLUSIONS

1x 15amp Plug and Lead
1x 1m Flexible Water Connection Hose
1x 1m Flexible Waste Hose
1x 500 x 500 Flat Rack
1x 500 x 500 Plate Rack

### STANDARD FEATURES

- Touch display with glass surface
- Vario power warewashing system for adjustable pressure
- Quadruple filtration system with clouding sensor
- Fully insulated
- Drain pump
- Rinse booster pump
- Integrated chemical dosing with storage tanks for rinse aid and detergent